

PAS3 Z-PH20 'MM' Phono Preamp Upgrade Kit

Assembly And Installation Instructions

v1a 07-2025

Introduction

- The PAS2/3 was the most popular tube Preamplifier ever made.
- It was produced from 1960 until around 1985. Two features that made it so popular were it's low price and it's simple construction. The circuitry was far from state-of-the-art, but in the early years of it's production it was considered a decent performer and excellent value.
- Unfortunately Dynaco went out of business in the mid 80's and although other budget Preamp's were available by that time the cost was double or triple so the PAS2/3 series remained very popular in the aftermarket as used units.
- During the late 80's and early 90's a few aftermarket modifications became available and the most popular of those remain today. Unfortunately for most users, the modifications themselves were more expensive than a newer Preamp and thus a poor value.

The Circuit Design

- Our PAS3-Z modification replaces the original circuit design with a modern tube MM Phono Preamp circuit.
- The PCB's are sized to fit perfectly into the existing PAS3 chassis without any modification of the chassis, and they mount in the same way using the original hardware.

Tube Information

- This circuit upgrade requires the user to buy a minimum of two new 12AY7 tubes that are used in the line amplifier. It is highly recommended that ALL tubes in the Preamp be replaced with NEW tubes. Tube characteristics often change with age and wear out.
- In other words, a fresh 12AY7 is not the same as that old 12AY7 after 20 years of use.
- Fortunately the 12AY7 is a very common tube and there are many dozens of available types and brands that can be used. We would like to comment though that on the budget side, we prefer using the EH or JJ brand for the 12AY7. Of course if you have some good quality NOS or used Telefunken or Mullard's, use those.
- NOTE: tubes require 24VDC for the filaments, NOT 6.3V or 12.6VDC!

No Negative Feedback Loop

- The new circuit topology does NOT use any negative feedback.
- In the old circuit this was especially part of the Phono design, and also used in the tone control section of the old line amplifier.
- This is one of the main reasons the original circuit had major limitations on maintaining gain and bandwidth with accurate reproduction.
- Unlike negative feedback that has to wait until something goes wrong before it can work to undo the damage.
- The proper design of a modern circuit can eliminate negative feedback and do the proper job in the first place without any band-aid type fixes, while reducing tube noise by using less gain to accomplish the job with lower distortion and coloration of the sound.

Grounding

- If everything is connected as shown in the diagrams then there should be no noise or hum problems.
- Ground loops though can potentially be a problem especially in any Preamp project.
- For example, if the RCA jacks are not isolated from the chassis, then the twisted pair of wires that connect the PCB to the jacks will each define a ground loop. The solution is either to isolate the jacks or use only a single hot wire from jack to PCB (the wire can be shielded, as long as the shield only attaches at one end).
- Thus, the best plan is to plan ahead and do it correctly the first time.
- Three different schools of thought hold for grounding a piece of audio gear.
- The **Old-School** approach is to treat the chassis as the ground; period.
- This was especially common on the older Dynaco amps and Preamp's.
- Every ground connection is made at the closest screw and nut.
- This method is the easiest to follow and it produces the worst sonic results.
- The Z-H20 was designed to help eliminate any ground loop problems by careful design of the PCB traces, and by following good wiring practices when connecting the PCB's to each other and to the volume/balance controls, and RCA input-output jacks.

House Ground

- The third prong on the wall outlet attaches to the house's ground, usually the cold water pipe.
- In the original Dynaco Preamp a two-line power cord is used, which means the chassis itself is NOT connected to the AC power ground. This is usually not a problem, but potentially it can allow some sort of ground loop problem when other system components (CD player, turntable, amplifier) are connected to it.
- Usually with a two-line power cord you can eliminate or resolve this problem by unplugging the power cord and then reversing it's direction into the AC outlet.
- Another good idea is to plug all components into a common power strip.
- The pre-amplifier CAN use a 3 wire cord and attach the chassis to ground, which is certainly the safest approach, as it provides a discharge path should the B+ short to the chassis.
- Unfortunately, this setup often produces a hum problem. Some simply float the ground, which is the way we usually wire our Preamp's, and others use a 10-ohm resistor parallel shunted by a small capacitor, say 0.01 μ F 250V, connected from chassis to AC ground.
- A good test procedure is to detach all the signal inputs and all the output connection from the pre-amplifier.
- Then measure the AC voltage between the pre-amplifier chassis and the house ground. If it reads more than a few volts, try reversing the pre-amplifier plug as it plugs into the wall socket.
- Use which-ever orientation that results in the lowest AC voltage reading. Then measure the chassis ground to the first signal source's ground (while the signal source is turned on). Once again flip the signal source's plug until the lowest AC voltage setting is found. Then do the rest with the rest of the system.
- The results can prove far more satisfying than what would be yielded by buying thousand-dollar cables.

RFI

- Radio frequency interference can be a hassle to track down and eliminate.
- First make sure that the source of the problem actually resides in the pre-amplifier.
- For example, if only one signal source suffers from RFI noise, make sure that it is normally RFI free. In other words, attach it to another pre-amplifier and see if the RFI persists. If it does pass this test, then try soldering small capacitors, say 100pF, from this signal source's RCA jacks to the chassis, as close as possible to the jacks if it fails, fix the source.

Solder Skills

We cannot stress more the importance of good soldering practice. 95% of all issues with a build that we come across is bad soldering. Dry/Cold solder joints are most of the issues. Please Ensure That Your Soldering Skills Are Very Good, See The Below Examples

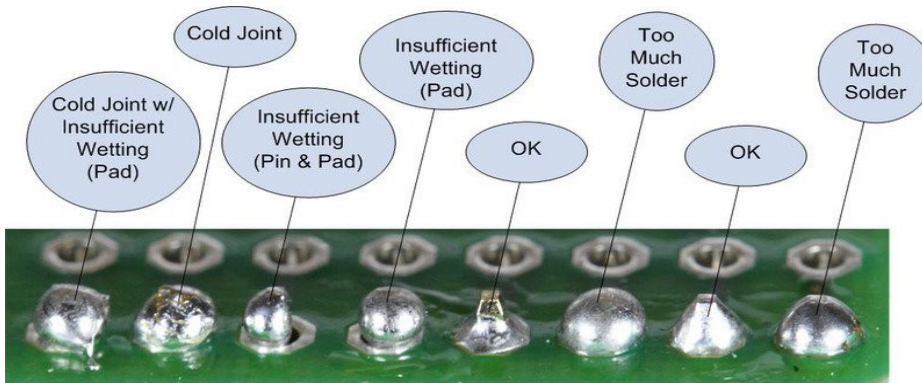

PCB Assembly Directions

Refer To The PCB Layout Diagrams And Parts List Below.

- Start by inserting the resistors onto the PCB's and solder them in place.
- Next insert the tube sockets and solder them in place.
- Next insert the smaller capacitors and solder them in place.
- Then insert the larger capacitors and solder them in place.
- If you haven't already done this, remove the original PCB's from the chassis.
- Cut off all the wires that attached the tone controls to the original PCB's, the tone controls will not be used with this modification.
- Cut off the wires that attached the FILTER switch to the original PCB's, the FILTER switch will not be used with this modification.
- Now you can mount the Z-PH20 Phono board to the chassis, from the bottom side, using the original hardware.
- Refer to the chassis layout below for correct orientation of the PCB's.
- A note about resistors: Some 1/2W resistors look like the size of 1/4W, but they are in fact 1/2W and can generally be told apart from 1/4W as they tend to have thicker gauge leads. They are perfectly fine to be used in 1/2W placings. Also, a 1W resistor may be the size of a 1/2W resistor, with modern and different materials, manufacturers are able to decrease the size of a component.

Testing

- Before testing, visually inspect the PCB for proper parts placement and soldering quality connections.
- Make a habit of using only one hand, with the other hand behind your back, while attaching probes or handling high-voltage gear, as a current flow across your chest can result in death.
- In addition, wear rubber-soled shoes and work in a dry environment.

Remember, safety first, second, and last.

- If possible, use a Variac and slowly bring up the AC voltage, while looking for smoke or part discoloration or bulging.
- Only after you are sure that both heater and B-plus power supplies are working well, should you attach the line-stage amplifier to a power amplifier.

Circuit Diagram

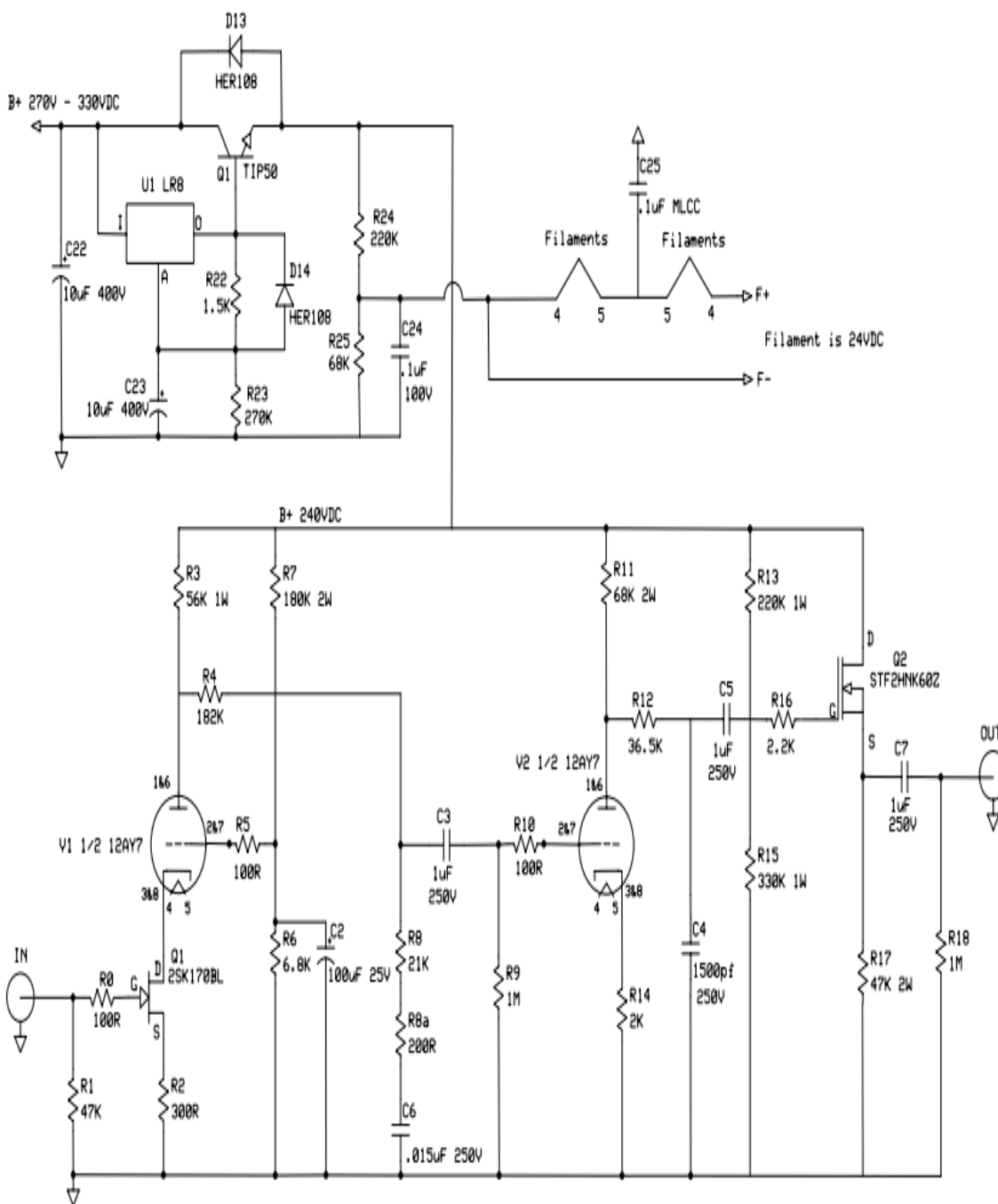

NOTE:

- One channel shown
- Capacitor voltage rating may change depending on availability
- Some slight variations in resistor values may be possible
- Any component value variations will not affect operation

PAS3 Upgrades

PAS Z-PH20 Phono Preamp v1

HS

Rev 1

09/11/2023

1

Signal Wiring Diagram

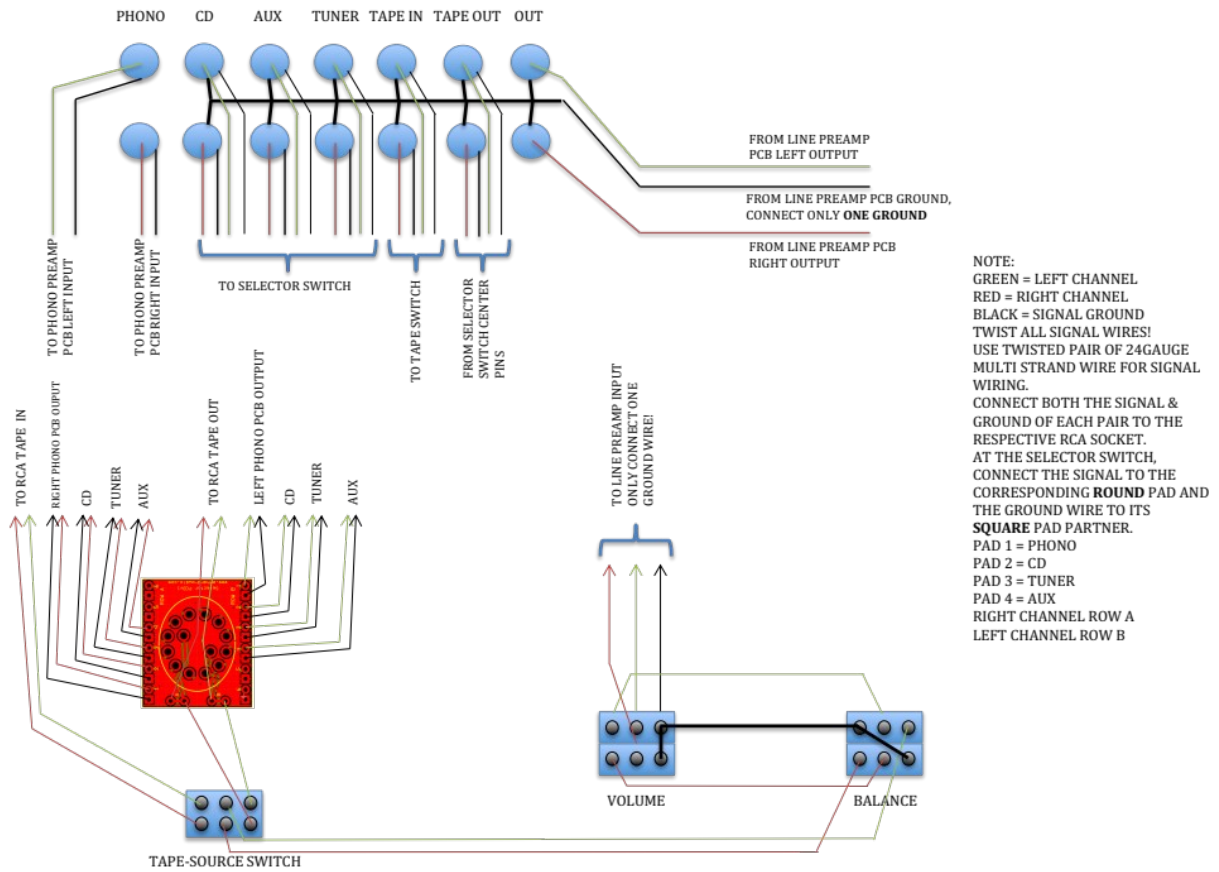

This Signal Wiring Diagram Is A General Indication Of How A PAS Upgraded With Our Kits Should Be Wired.

PCB LAYOUT

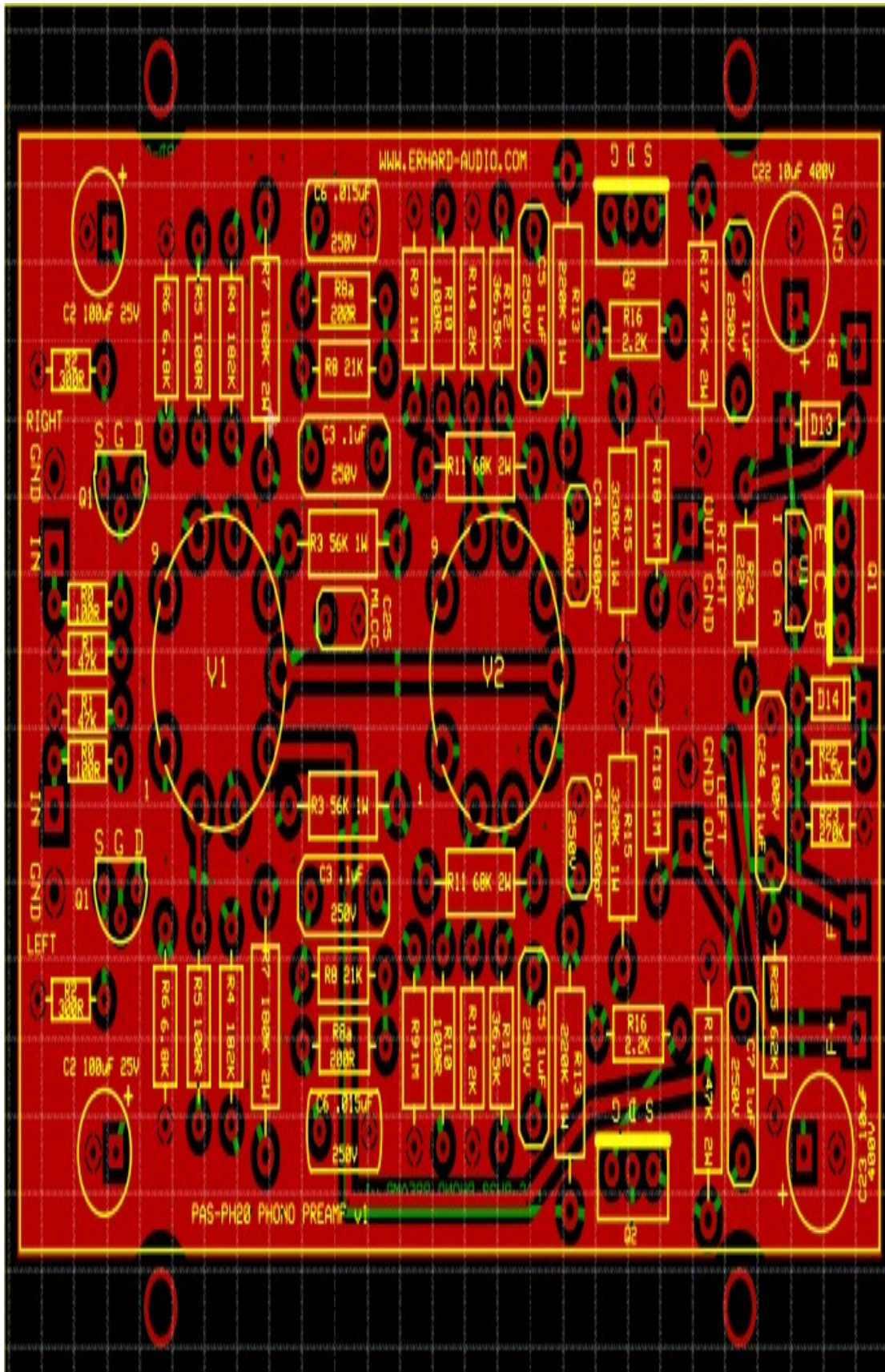

Typical Completed New Gen PAS Chassis Layout

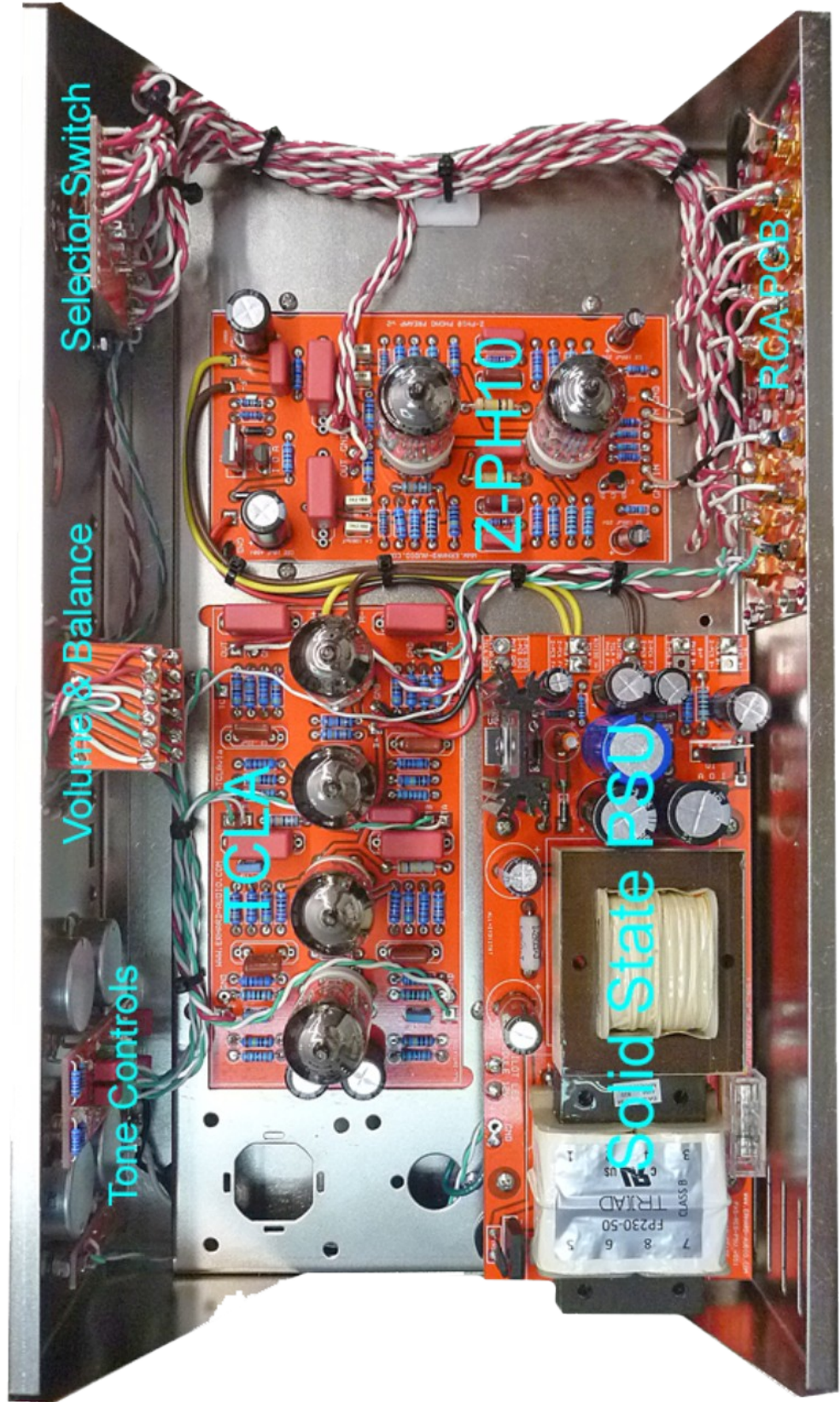

Parts List

PH20 Phono Preamp v1.00						
			Qty			Qty
	Resistors			PCB		
R0	100R 1/4W		2	PAS3 Z-PH20v1		1
R1	47K 1/4W		2			
R2	300R 1/4W		2	Sockets		Qty
R3	56K 1W		2	9 pin		2
R4	182K 1/2W		2			
R6	6.5K 1/2W		2			
R7	180K 2W		2			
R8	21K 1/2W		2			
R8a	200R 1/2W		2			
R9,R18	1M 1/2W		4			
R11	68K 2W		2			
R5,R10	100R 1/2W		4			
R12	36.5K 1/2W		2			
R13	220K 1W		2			
R14	2K 1/2W		2			
R15	330K 1W		2			
R16	2.2K 1/2W		2			
R17	47K 2W		2			
R22	1.5K 1/4W		1			
R23	270K 1/4W		1			
R24	220K 1/2W		1			
R25	62K 1/2W		1			
	Capacitors		Qty			
C2	100uF 25V		2			
C3	0.1uF 250V	10mm	2			
C4	1500pF 250V	5mm	2			
C5,C7	1.0uF 250V	10mm	4			
C6	0.015uF 250V	10mm	2			
C22,23	10uf 400uF		2			
C24	0.1uF 100V	10mm	1			
C25	MLCC	5mm	1			
	Smiconductors		Qty			
Q1,	2SK170BLF		2			
Q2	STF2HMK60Z		2			

5 Band Resistor Color Coding

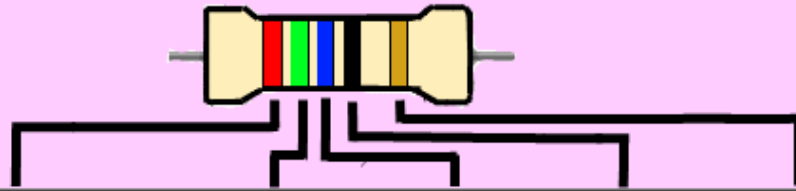

COLOR	1ST BAND	2ND BAND	3RD BAND	MULTIPLIER	TOLERANCE
BLACK	0	0	0	x1Ω	
BROWN	1	1	1	x10Ω	±1%
RED	2	2	2	x100Ω	±2%
ORANGE	3	3	3	x1000Ω	
YELLOW	4	4	4	x10000Ω	
GREEN	5	5	5	x100000Ω	±0.5%
BLUE	6	6	6	x1000000Ω	±0.25%
VIOLET	7	7	7	x10000000Ω	±0.1%
GREY	8	8	8		±0.05%
WHITE	9	9	9		
GOLD					±5%
SILVER					±10%

How To Read Capacitor Codes

Large capacitors have the value printed plainly on them, such as 10.uf (Ten Micro Farads) but smaller disk types along with plastic film types often have just 2 or three numbers on them?

First, most will have three numbers, but sometimes there are just two numbers. These are read as Pico-Farads. An example: 47 printed on a small disk can be assumed to be 47 Pico-Farads (or 47 pF as some like to say)

Now, what about the three numbers? It is somewhat similar to the resistor code. The first two are the first and second significant digits and the third is a multiplier code. Most of the time the last digit tells you how many zeros to write after the first two digits, but the standard (EIA standard RS-198) has a couple of curves that you probably will never see. But just to be complete here it is in a table.

Third Digit	Multiplier (this times the first two digits gives you the value in Pico-Farads)
0	1
1	10
2	100
3	1,000
4	10,000
5	100,000
6 not used	
7 not used	
8	.01
9	.1

Now for an example: A capacitor marked 104 is 10 with 4 more zeros or 100,000pF which is otherwise referred to as a 0.1uF capacitor.

Most kit builders don't need to go further, but I know you want to learn more. Anyway, Just to confuse you some more there is sometimes a tolerance code given by a single letter. I don't know why there were picked in the order they are, except that it kind of follows the middle row of keys on a typewriter. So a 103J is a 10,000 pf with +/-5% tolerance

	Tolerance of capacitor
D	+/- 0.5 pf
F	+/- 1%
G	+/- 2%
H	+/- 3%
J	+/- 5%
K	+/- 10%
M	+/- 20%
P	+100% , -0%
Z	+80%, -20%

Picofarad (pF)	Nanofarad (nF)	Microfarad (uF)	Code	Picofarad (pF)	Nanofarad (nF)	Microfarad (uF)	Code
10	0.01	0.00001	100	4700	4.7	0.0047	472
15	0.015	0.000015	150	5000	5.0	0.005	502
22	0.022	0.000022	220	5600	5.6	0.0056	562
33	0.033	0.000033	330	6800	6.8	0.0068	682
47	0.047	0.000047	470	10000	10	0.01	103
100	0.1	0.0001	101	15000	15	0.015	153
120	0.12	0.00012	121	22000	22	0.022	223
130	0.13	0.00013	131	33000	33	0.033	333
150	0.15	0.00015	151	47000	47	0.047	473
180	0.18	0.00018	181	68000	68	0.068	683
220	0.22	0.00022	221	100000	100	0.1	104
330	0.33	0.00033	331	150000	150	0.15	154
470	0.47	0.00047	471	200000	200	0.2	254
560	0.56	0.00056	561	220000	220	0.22	224
680	0.68	0.00068	681	330000	330	0.33	334
750	0.75	0.00075	751	470000	470	0.47	474
820	0.82	0.00082	821	680000	680	0.68	684
1000	1.0	0.001	102	1000000	1000	1.0	105
1500	1.5	0.0015	152	1500000	1500	1.5	155
2000	2.0	0.002	202	2000000	2000	2.0	205
2200	2.2	0.0022	222	2200000	2200	2.2	225
3300	3.3	0.0033	332	3300000	3300	3.3	335

We cannot take ANY responsibility for mains, and for that matter, ALL high voltage AC and DC wiring you carry out. We have described in this, and all of our other manuals, as best as we can, on how to wire up these high voltage connections. You MUST take EXTREME care, that no wires are shorted together, or to the chassis, or any other part of the assembly and PCB's. All these high voltages can be life threatening, and can hurt you or others if carried out incorrectly. Use your meter in the continuity setting to make sure no high voltage wires are shorted together or to chassis ground. Apart from bodily harm, incorrect high voltage wiring can and will damage components! You are totally and solely responsible for all high voltage wiring and the general assembly of this kit! We have wired our prototype amp exactly as described in this and all of our other manuals, so we know that the amp will work as designed and intended!

If you are unsure of how to carry out some of our instructions, PLEASE contact us via e-mail, we provide, as part of our service, full support for this and all of our kits! No question is stupid. The ONLY stupid question is the one you do not ask!